



Operating Manual

Bevelling machine UZ20

Table of contents

1. General safety instructions	3
2. Construction	4
2.1 Front	4
2.2 Rear / control section	5
2.3 Feed unit front.....	6
2.4 Feed unit rear	7
3. Operating controls	8
3.1 Front	8
3.2 Rear / control section	8
3.3 Feed unit.....	9
4. Labelling	10
4.1 General information	10
4.2 Specifications.....	11
4.3 Installation data / dimensions.....	13
5. Intended usage.....	13
5.1 Application, consequences, usage.....	13
5.2 Organisational measures	14
5.2.1 Machine usage site	14
5.2.2 Sound insulation table.....	14
5.2.3 Transportation.....	15
5.2.4 Space requirement.....	16
5.2.5 Energy connection	17
5.2.6 Location of operator's manual.....	17
5.2.7 User requirement / operating personnel.....	17
5.2.8 Performance of work on the bevelling machine	17
5.3 Protective devices.....	18
5.4 Personal protective equipment	19
6. Operating modes.....	20
6.1 Construction, putting into operation and disassembly.....	20
6.2 Normal operating mode	21
6.3 Removing the workpiece.....	27
6.4 Rectifying a device malfunction	28
6.5 Servicing	28
6.6 Maintenance	29
7. Additional notes.....	32
7.1 Optional extras.....	32
7.2 Service.....	36
7.3 Disposal.....	36
8. Replacement parts	36

ANNEX

1. General safety instructions

This chapter highlights all basic safety instructions that must be complied with by users who operate a plate chamfer machine, as well as third parties.

All points contained in these safety instructions must be read and understood before the machine is taken into operation.

Explanation of symbols



You will see this symbol next to all work-safety instructions in this operator's manual where there may be a hazard to the life and limb of persons.



You will see this symbol next to all system instructions in this operator's manual that warn of electrical voltage.

Safety instructions



- Never touch rotating parts.
- Wear **protective goggles**, **ear muffs** and **protective gloves** whenever you carry out milling work on the machine.
- Persons who are close to the machine must also wear protective goggles as turnings may be ejected from the machine.
- The master switch must be switched off and secured by a padlock whenever service, maintenance and cleaning tasks are performed on the machine.
- All safety instructions contained in the following chapters of this Operating Manual must be complied with.
- The machine is only to be operated in compliance with the instructions contained in this Operating Manual.

2. Construction

2.1 Front

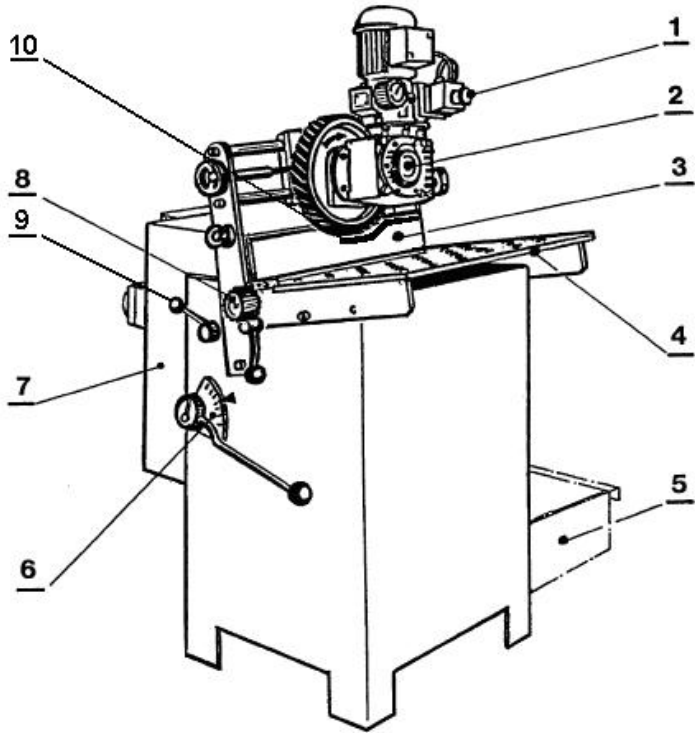

Legend:

- 1) EMERGENCY STOP switch
- 2) Workpiece feed unit (see sep. illustration Page 6/7)
- 3) Guide rails for workpiece carrier
- 4) Ball castor table
- 5) Drawer for millings
- 6) Milling angle adjuster (UZ20)
- 7) Control cabinet (see sep. illustration Page 5)
- 8) Milling depth regulator
- 9) Locking lever
- 10) Hand protective guard

2.2 Rear / control section

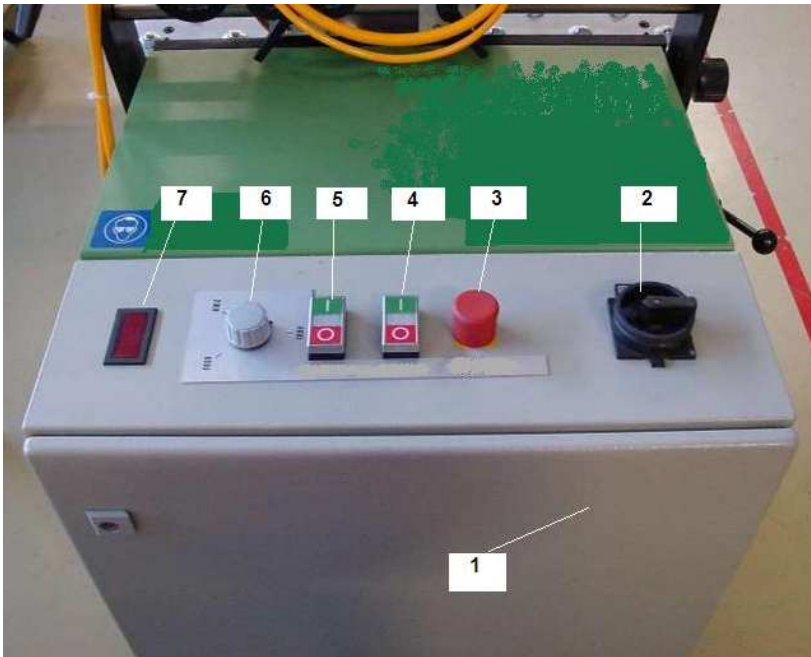

Legend:

- 1) Control cabinet
- 2) Master switch
- 3) EMERGENCY STOP switch
- 4) Feed ON / OFF
- 5) Milling spindle ON / OFF
- 6) Speed controller
- 7) Speed indicator (frequency; 50 Hz = 3000 rpm)

2.3 Feed unit front

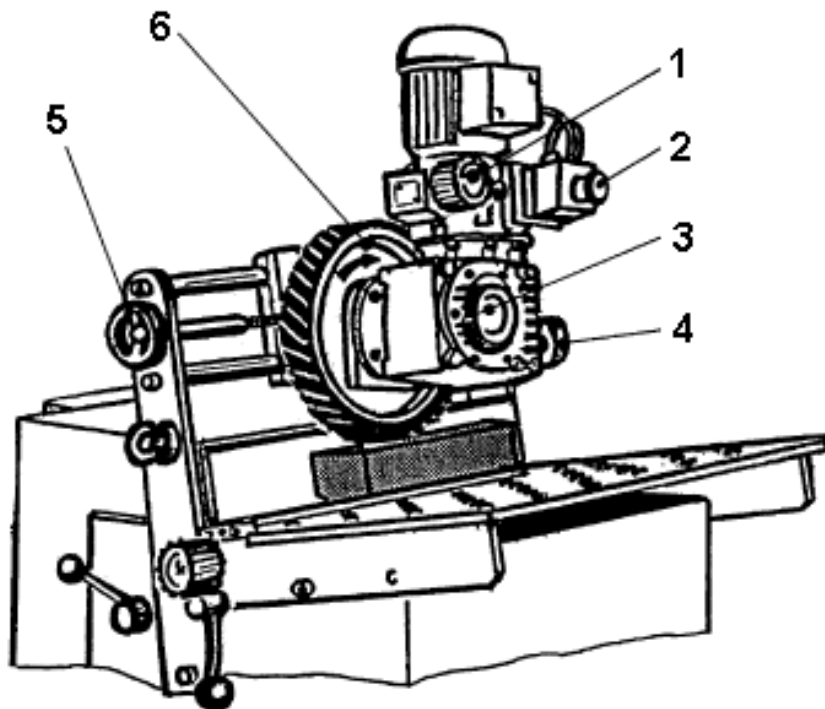

Legend:

- 1) Feed speed controller
- 2) EMERGENCY STOP switch
- 3) Drive with variator and gearbox
- 4) Handwheel for feed unit height adjustment
- 5) Adjuster for feed wheel position
- 6) Feed wheel

2.4 Feed unit rear

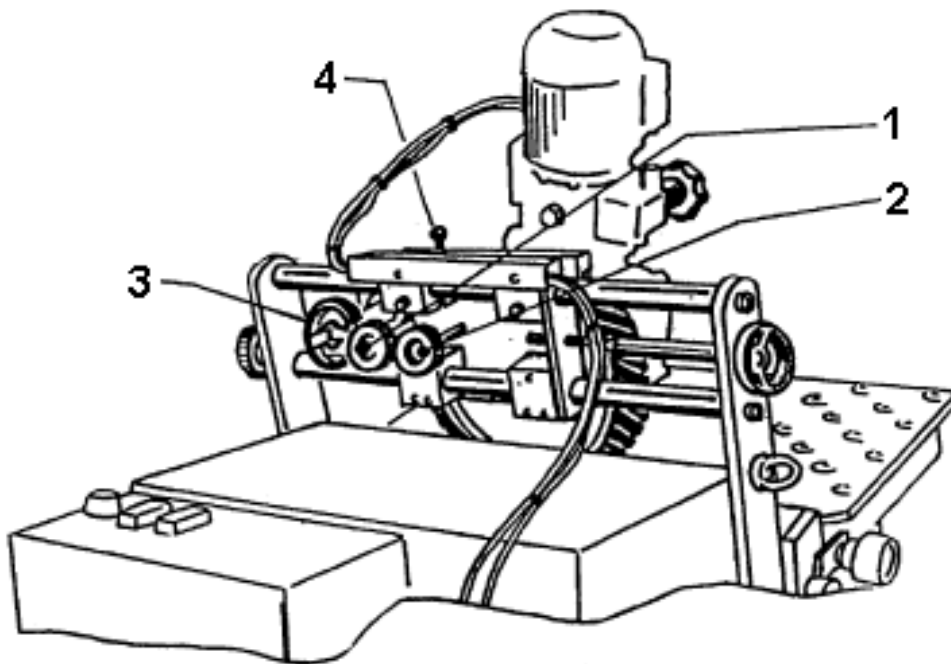

Legend:

- 1) + 2) Handwheels for infinitely variable adjustment of the feed unit angle
- 3) Handwheel for adjusting the distance of the feed wheel to the rear guide rail
- 4) Clamping lever

3. Operating controls

The most important machine operating controls are explained to the user in this chapter. The other operating controls are explained successively in the following chapters.

3.1 Front

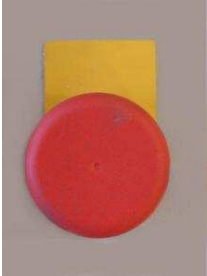

EMERGENCY STOP switch (red / yellow)

- Emergency stop device for moving the machine from an unsafe state into a safe state
- Stops the rotary movement of the milling spindle and the feed wheel



Milling depth regulator (black / white)

- Gravitation meter display integrated
- For infinitely variable adjustment of the chamfer depth

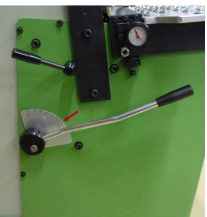

Milling angle adjuster (UZ20)

- For infinitely variable adjustment of the milling angle (30°– 60°)
- The locking lever (see Page 4, Item 9) must be released before adjustment and tightened afterwards

3.2 Rear / control section

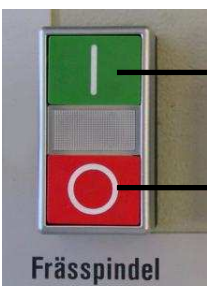

Milling spindle ON (green)

Push button. Switches on the milling spindle rotary movement.

Milling spindle OFF (red)

Push button. Switches off the milling spindle rotary movement.

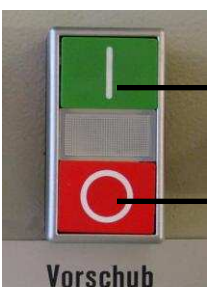

Feed ON (green)

Push button. Switches on the feed wheel rotary movement.

Feed OFF (red)

Push button. Switches off the feed wheel rotary movement.

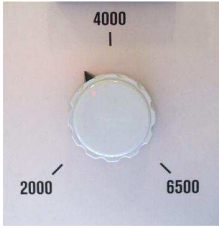

Speed controller (white)

- Rotary knob
- For infinitely variable adjustment of the milling spindle wheel



Master switch (black)

- Lockable by means of a padlock
- For electrical maintenance work on the system with the power off
- Acts upon all potentially hazardous movements and energies

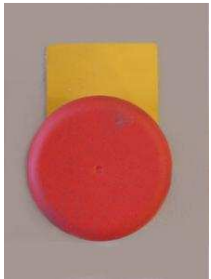

EMERGENCY STOP switch (red / yellow)

- Emergency stop device for moving the machine from an unsafe state into a safe state
- Stops the rotary movement of the milling spindle and the feed wheel

3.3 Feed unit



Feed speed controller (black / white)

- Gravitation meter display integrated
- Used for infinitely variable adjustment of the feed speed



Handwheel for feed unit height adjustment (black)

- Used for infinitely variable adjustment of the height between the workpiece and feed wheel



EMERGENCY STOP switch (red / yellow)

- Emergency stop device for moving the machine from an unsafe state into a safe state
- Stops the rotary movement of the milling spindle and the feed wheel

4. Labelling

4.1 General information

Product name: Bevelling machine UZ20

Model designation UZ20

Serial number:

CE identification: CE

Year of manufacture:

4.2 Specifications

Equivalent permanent sound pressure level:

(Dependant upon the chamfer depth, material, feed speed, milling angle and quality of the carbide reversing plates)

Mean average value:	85 dB(A)
Min:	75 dB(A)
Max:	95 dB(A)

- Milling spindle drive:

Spindle speed range: 2000 – 5500 rpm

Milling spindle power output: 3.0 kW UZ20

- Feed drive:

Feed speed: 0.5 – 5 m/min.

Three-phase motor power output: 0.55 kW

- Milling head:

UZ20: Milling head dia. 80 mm, positive, with 6 ISO standard reversing plates

- Surface finish

Above N7, no chatter

- Electrical:

Installed power: 3.5 kW

Connection voltage: 380 V

Frequency: 50 Hz

Installation in accordance with VDE

4.3 Installation data / dimensions

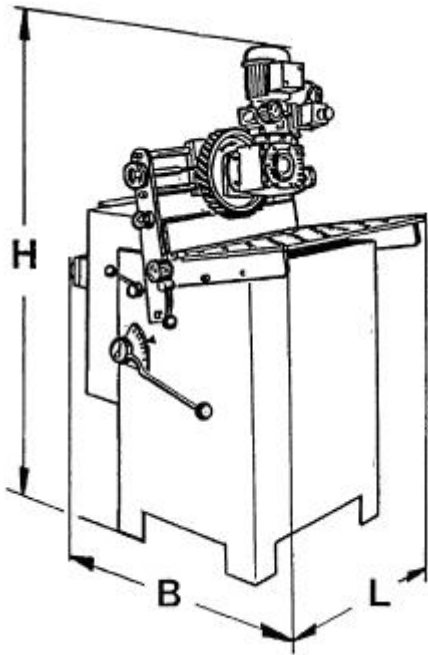

Dimensions:

L (Length): 900 mm
1100 mm
H (Height): 1650 mm

Weight: 400 kg

Electrical connection
voltage: 400 V

Frequency: 50 Hz

5. Intended usage

5.1 Application, consequences, usage

The plate chamfer machine has been constructed in accordance with the applicable state of the technological art and the recognised safety engineering regulations.

- Application
 - For optimum milling of welded edges and chamfers
 - For machining long and short workpieces made out of steel, V2, V4A, aluminium alloys, copper, brass, synthetic material, etc.
 - For simple deburring
- Consequences of improper usage
 - Hazard to the limb and life of the user or third parties
 - Impairments to the machine and other material assets

- Usage

- Operating personnel must be thoroughly instructed prior to usage
- The machine may only be used when it is in a perfect technical condition
- The machine user's behaviour must always be safety aware and hazard aware
- All machine usage must be in accordance with the Operating Manual
- The machine may only be operated in fault-free and safe environments
- Maintenance requirements must be complied with whenever the machine is used

Note

- Any application different to that described above is not permitted
- The manufacturer or supplier is not liable for damage arising from usage if the machine is used for applications other than those described. The user alone is responsible for this type of risks.

5.2 Organisational measures

5.2.1 Machine usage site

The machine usage site must satisfy the following requirements in order to guarantee that operation is safe and free from faults:

- The UZ20 must be erected on level, non-slip ground
- The connection cable must be routed so that it cannot be a source of stumbling
- The UZ20 must be screened with noise barriers (approx. 2 m high) if required

5.2.2 Sound insulation table

The table below shows guide values with regard to noise emission from the machine so that you can undertake suitable sound insulation measures.

Material	Chamfer height at 45°	Speed	DBA
St 37	3 mm	3500	80
St 37	5 mm	3800	85
1.4301	3 mm	2800	85
1.4301	5 mm	3000	90
Aluminium	5 mm	5000	88
Tool steel			
1.2510	3 mm	2800	88
1.2510	5 mm	2800	90

5.2.3 Transportation

The UZ20 can be transported by different methods:

- Transportation by crane:

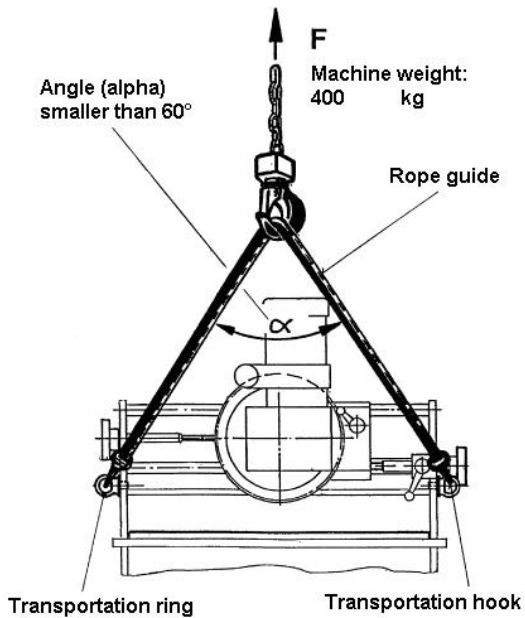

Two transportation rings for machine transportation are fitted on the feed unit beams. The rope guide should be fitted as shown in the adjacent sketch in order to guarantee optimum transportation without damage.

- Transportation by pallet stacker

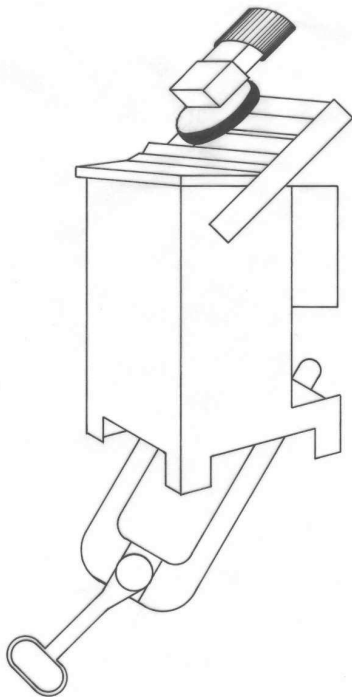

A pallet stacker can be used for transportation. Transport the machine as shown in the sketch.

- Transportation by fork-lift truck

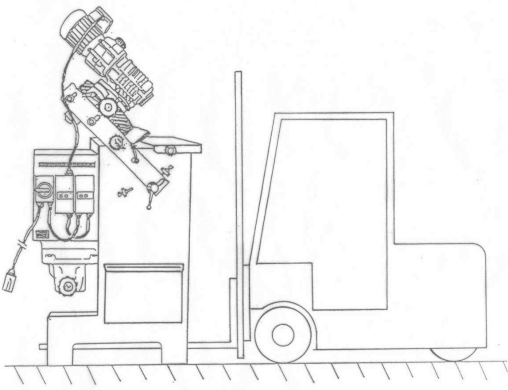

Comply with the adjacent sketch for transporting the UZ20 by a fork-lift truck.



- Always exercise care when pushing the machine. The machine may tip over when driving over uneven ground.
- The machine must be properly secured for transportation

Note

- The UZ20 must be disconnected from all energy supplies even if its location is only changed by a small amount. The machine must be properly connected to the power supply prior to being taken back into operation.
- Only use procedures shown in the operator's manual for taking the machine back into operation.

5.2.4 Space requirement

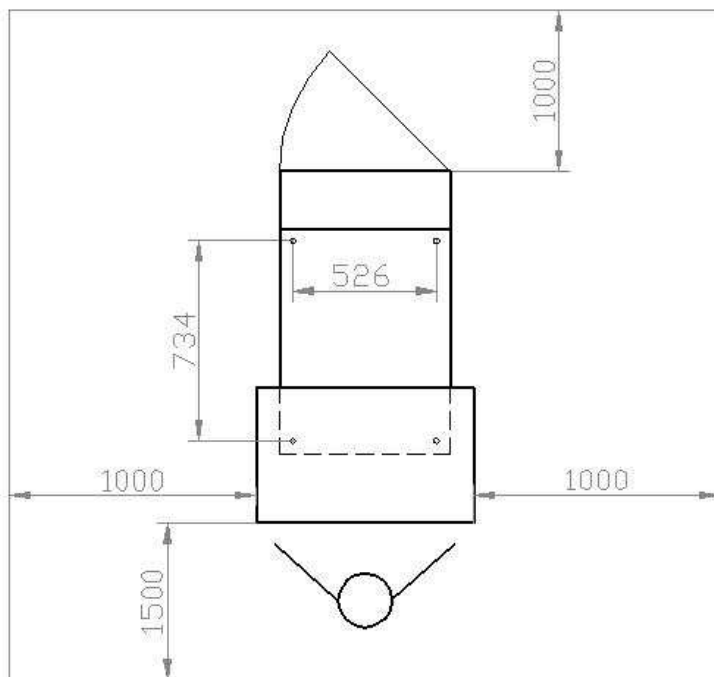

View from above

5.2.5 Energy connection

The UZ20 is operated solely by electricity. Compliance of the local voltage with the installation data must be ensured (see Installation data / dimensions, Chapter 4.3).

5.2.6 Location of operator's manual

The operator's manual must be permanently kept ready to hand at the machine's usage site.

5.2.7 User requirement / operating personnel

- Only trained and instructed personnel are to operate the UZ20. The legally permissible minimum age must be complied with.
- Personnel undergoing training, teaching, instruction or who are on a general training course must always be placed under the constant supervision of an experienced person.
- Personnel responsibilities for operating, servicing and maintenance must be clearly specified.
- It must be ensured that only authorised personnel work on the machine.

5.2.8 Performance of work on the UZ20

- Personnel authorised to work on the machine must have read and understood the operator's manual prior to machine start-up.

Read and understand the Operating Manual firstly. It is too late when working.

- The generally applicable, legal and other binding provisions for accident prevention and environmental protection in the country in which the machine is operated apply as being supplementary to the Operating Manual.
- Only specialist personnel or technicians after consultation with our specialist personnel may perform mechanical and electrical work on the UZ20. All other persons are forbidden to perform repairs or modifications to the machine.
- Replacement parts must satisfy the technical requirements stipulated by the manufacturer. Only original replacement parts must be used.

5.3 Protective devices



EMERGENCY STOP switch (red / yellow)

- Primary emergency stop device for preventing injury to persons and damage to property



Milling spindle OFF (red)

- Device for switching off the milling spindle during production interruptions

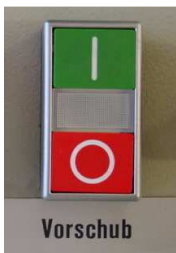

Feed OFF (red)

- Device for switching off the feed during production interruptions



Master switch (black)

- Device for switching off for servicing and maintenance work on mechanical components of the UZ20.
- Pull out the plug and disconnect the machine from the mains power supply when carrying out electrical maintenance work.
- Emergency stop device for preventing injury to persons and damage to property



Hand protective guard



- The yellow hand protective guard on the feed wheel is to be adjusted to the material thickness. **Never mill without this protective guard.**

Adjustment of the hand protective guard

1. Slacken screw (2)
2. Set the protective slide (1) to a distance of 3 mm from the workpiece (see illustration)
3. Tighten screw (2)

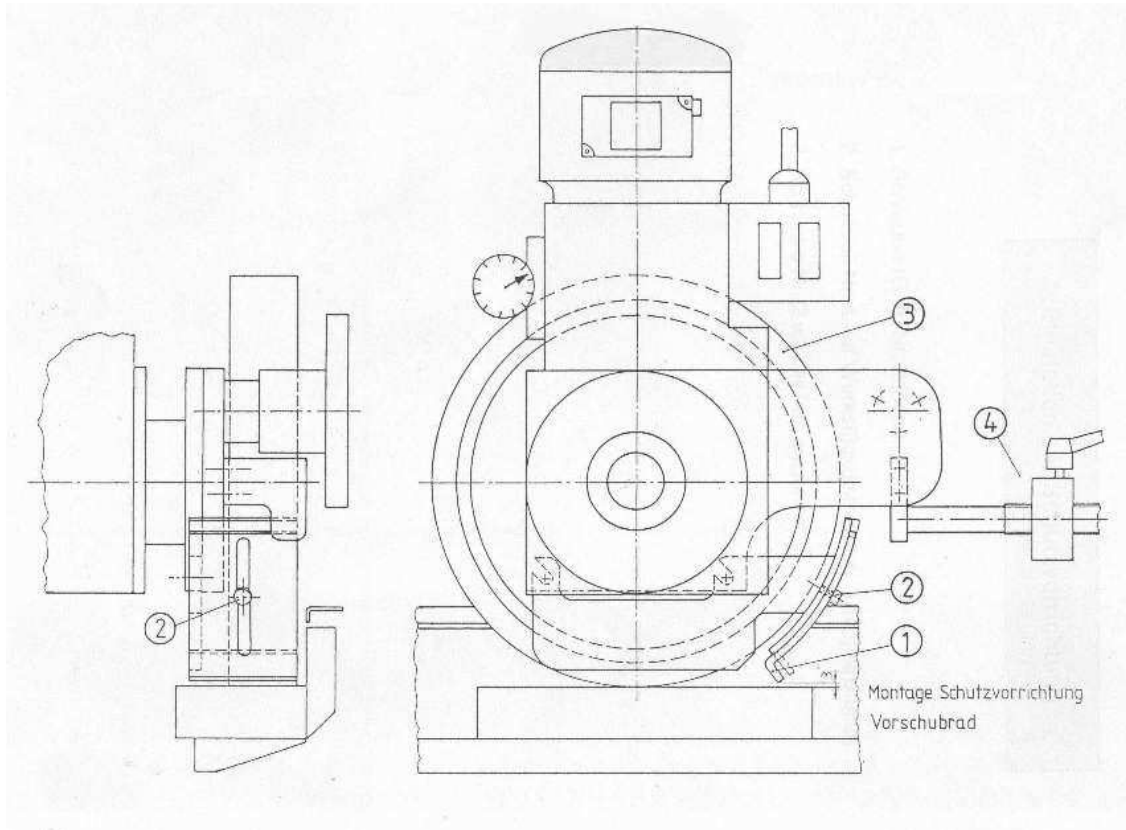

- All working methods with dubious safety aspects are forbidden.
- Only ever operate the UZ20 when all protective devices and safety devices are fitted and operable.
- The machine should be regularly inspected for externally recognisable damage and defects. Any changes that occur (including the operating characteristics) are to be reported immediately to the responsible centre / person. The machine must be stopped immediately and secured by the master switch if need be.
- Stop and secure the UZ20 immediately in the event of malfunctions. Rectify malfunctions immediately.
- Procedures for switching on and off must comply with the Operating Manual.



5.4 Personal protective equipment

The protection devices below must always be worn when using the UZ20:

- Protective goggles
- Ear muffs
- Protective gloves

6. Operating modes

6.1 Construction, putting into operation and disassembly

Construction

The plate chamfer machine is delivered fully assembled and ready for operation. Actual construction is therefore not necessary.

Putting into operation



- Only take the machine into operation when it is on level ground
- Check the connection cable for damage
- Route the cable so that it cannot be a source of stumbling
- **Electrical connection may only be performed by specialist personnel.**

Switching the machine on

(For operating controls see Chapter 3)

1. Plug in the mains power cable
2. Switch the master switch to ON
3. Push the green push button "Milling spindle ON"
4. Push the green push button "Feed ON"



Check the feed and milling spindle direction of rotation. The feed turns **clockwise**, the milling spindle in the **cutting direction**.

Note

The machine can be switched on and off at any set speed.

Switching the machine off

1. Press red push button "Feed OFF"
2. Press red push button "Milling spindle OFF"
3. Switch the master switch to OFF
4. Take the plug out of the socket if necessary

Machine disassembly

The UZ20 basic machine is not disassembled for transportation. See also the information in Chapter 5.2.3, Transportation.

6.2 Normal operating mode

The UZ20 normal operating mode is used to mill welded edges and chamfers

a) Adjusting the chamfer depth

The chamfer depth is set by means of a gravitation meter on the left hand side of the machine (see illustration on Page 4, Item 8). The chamfer depth is dependent upon the material to be machined as well as the quality of the carbide reversing plates.

The fundamental rules are:

- Better one machining process more – with smaller chamfer depths – than the other way around. This is how you save reversing plates.
- A smaller chamfer depth is used for small workpieces, while a larger chamfer depth per machine process is appropriate for large workpieces.

Small workpieces = smaller chamfer depth/process
Large workpieces = larger chamfer depth/process

- A surface finish of N7 is achieved with a finish machining process and a chamfer depth of 0.2 to 0.4 mm.

Experience values:

	Material	Chamfer depth 1st machining process	Chamfer depth further machining processes
UZ20	Structural steel St 37 to St 60 S 235 to E335	below 6 mm	2 – 4 mm
	Alloyed tool steel	2 – 4 mm	2 – 4 mm

Users should carry out tests themselves to determine the best values for their materials

Note

- The carbide reversing plates must be replaced if the machining is not clean
- Certain aluminium alloys cannot be machined without lubrication
Recommendation: Wet the edges to be milled with petrol or Tapmatic No. 2. A mist lubricator permanently installed underneath is ideal for mass production.
- Use only **new** carbide reversing plates to machine synthetic materials
- Non-ferrous metals such as copper, brass, etc. can be machined without any problems

b) Adjusting the feed unit position

Note

The feed wheel centre point should be above the milling spindle cutting point.

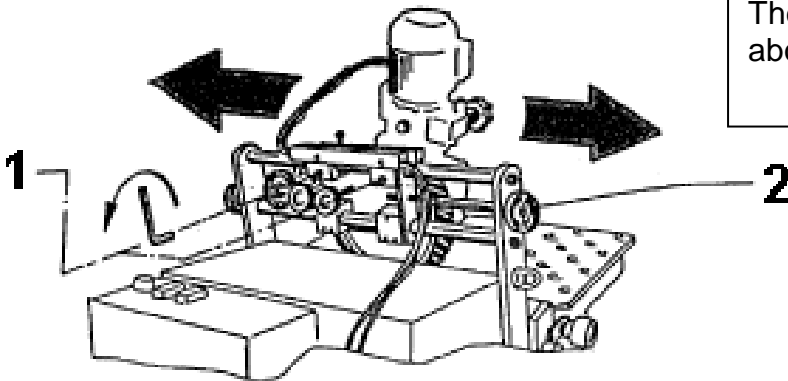

1. Slacken the two hexagonal socket screws or clamping lever (1) of the guides on the rear of the machine.
 - Push the feed unit to the **right** by hand (viewed from the front):
Turn the handwheel (2) anticlockwise to push the whole feed unit on the guides.
 - Push the feed unit to the **left** by hand: (viewed from the front):
Slacken the handwheel (2) clockwise. The feed unit pushes itself on the guides to the left driven by its own weight (must possibly be assisted).
2. Tighten the two hexagonal socket screws or clamping lever (1).

c) Feed unit height adjustment

The feed wheel must be adjusted to be approximately 2 – 5 mm lower than the height of the workpiece to be machined (see illustration)

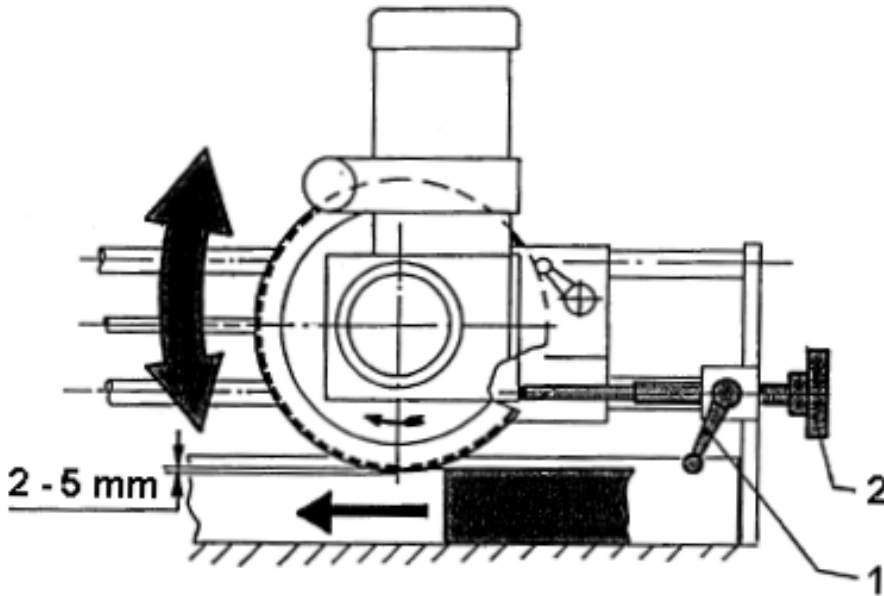

Procedure:

1. Slacken clamping lever (1)
2. Set the required height with the handwheel (2)
3. **Tighten clamping lever (1).**

Caution. Vibrations may cause the feed wheel to rest on the front guide rail, which would result in destruction of the feed wheel's rubber coating.

d) Adjusting the milling angle (UZ20)

The infinitely variably adjustable swivelling fixture for the milling unit allows all edges to be machined in the range 30°– 60°.

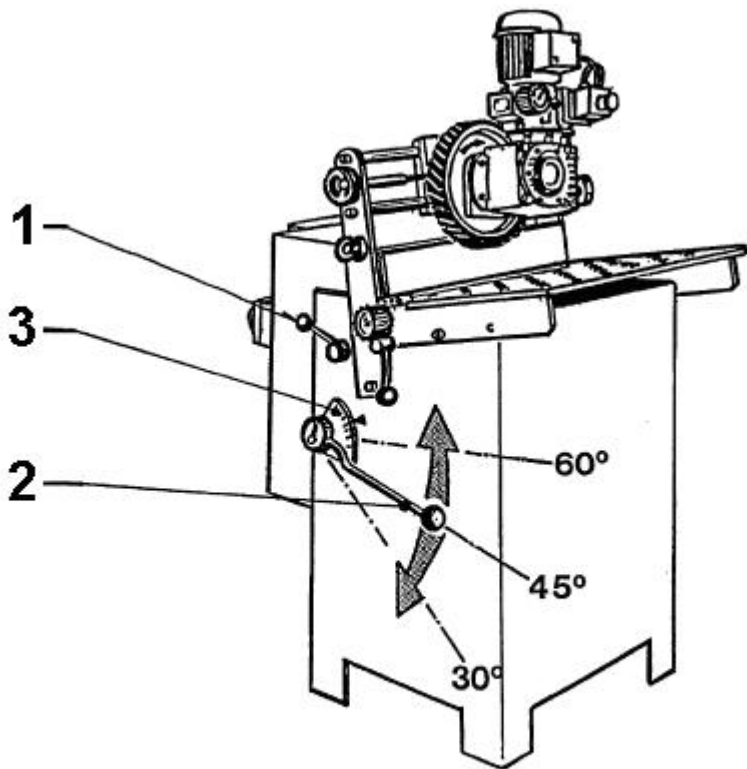

Procedure:

1. Slacken the locking lever (1)
2. Set the milling angle with the angle adjustment lever (2)
3. The angle can be read on the scale (3)
4. Tighten the locking lever (1)

e) Adjusting the milling spindle speed

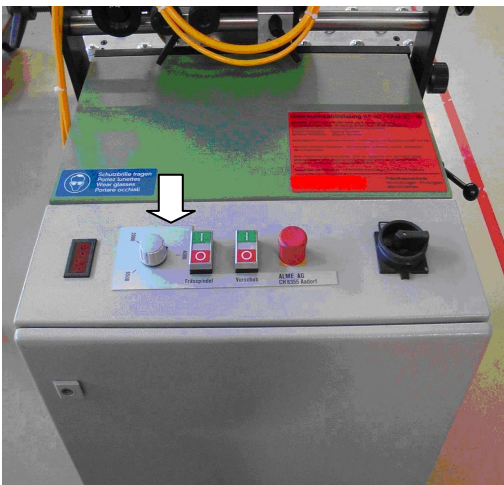

The ideal milling spindle speed is dependent upon the material to be machined. This speed can be set infinitely variably in the range from 2000 to 5500 rpm by means of the speed controller (arrowed) on the control box.

Note

The machine can be switched ON and OFF in all speed ranges.

Experience values:

	Speed (rpm)
Structural steel St 37 to St 60	2500 – 4000
Rustless material	2000 – 2800
Non-ferrous metals	Above 4500
Aluminium	5500
Synthetic materials	5500

f) Adjusting the feed speed

The feed speed can be set from 0.5 to 5 m/min infinitely variably at the handwheel by means of an integral gravitation meter. The speed is displayed on the gravitation meter.

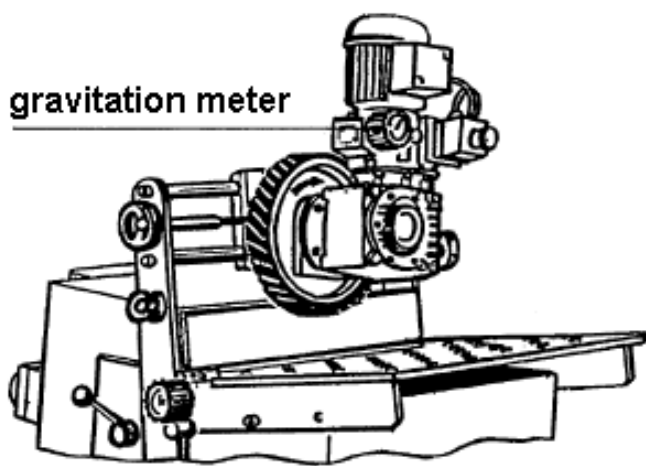

Note

- **Speed may only be adjusted for the variator when the motor is switched on. Never adjust during a stop (hazard of breaking).**
- The ideal feed speed is dependent upon the material to be machined, chamfer depth, required surface as well as the condition of the carbide reversing plates.
- The exact speed of the milling spindle can be determined by converting the frequency that is shown on the digital display (see Page 5, Item 7).

Reference: 50 Hz = 3000 rpm

g) Adjusting the angle and distance of the feed unit

The angle of the feed unit can be adjusted infinitely variably. This is easier to achieve when the feed wheel has been raised slightly from the lower guide rail and no workpiece lies in between. Slacken turning handle (2) and adjust the angle with turning handle (1) (must possibly be assisted a little by pulling the unit). Afterwards retighten turning handle (2).

The distance of the wheel to the rear guide rail is set by slackening the clamping lever (3) with the handwheel (4). The feed wheel is to be as close as possible to the guide rail, however without making any contact to it. Afterwards retighten the clamping lever (3).

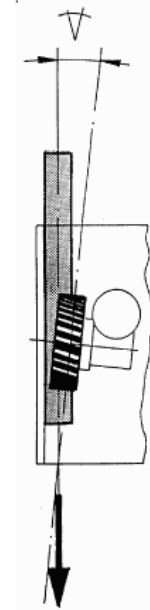
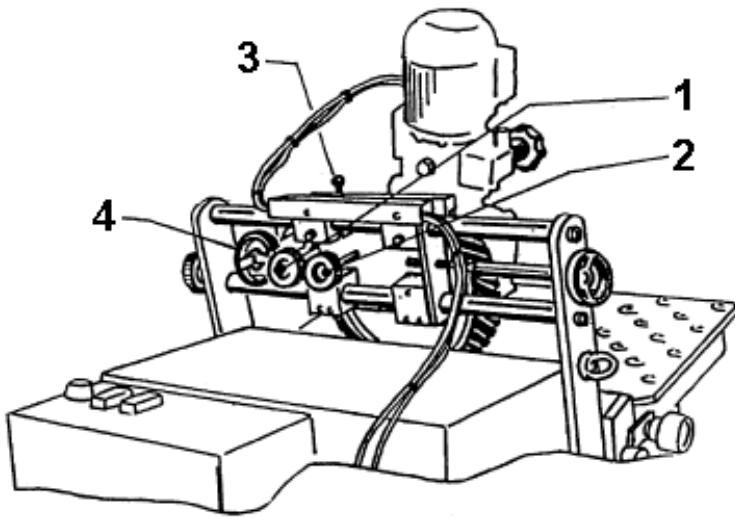

Note

- The feed unit is only to be angled to the workpiece axis up to the point when the workpiece easily runs through the machine
- Too much of an angle causes only unnecessary friction between the workpiece, feed wheel and guide rail

h) Switching the milling spindle on

The milling spindle is switched on at the push button "Milling spindle ON" (see Page 5, Item 5) at the control section on the rear of the machine.

i) Switching the feed on

The feed is switched on at the push button "Feed ON" (see Page 5, Item 4) at the control section on the rear of the machine.

Note

The feed only runs when the milling spindle is in operation.

j) Machining a workpiece

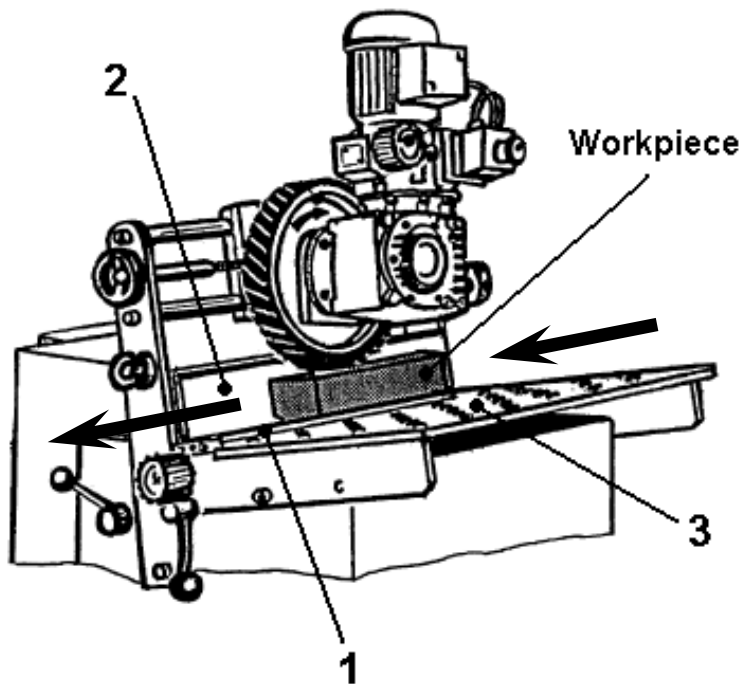

1. The workpiece is laid on the **right** of the feed wheel on the lower guide rail (1) or on the castor table (3) so that the workpiece touches the rear guide rail (2). The edge to be machined must lie in the gap between the two guide rails (1+2).
2. Now push the workpiece towards the feed wheel until the wheel engages the workpiece



Note

It is not possible for hands to be pulled along if the hand protective guard is fitted and correctly adjusted

6.3 Removing the workpiece

You can remove the machined workpiece from the left of the feed unit after the workpiece has run fully under the feed wheel.

6.4 Rectifying a device malfunction

A device malfunction on the UZ20 can be caused by the following:

- Overload of the milling spindle drive motor
- Overload of the feed drive motor

The two drive motors are fitted with thermal circuit breakers that automatically switch off the motors in the event of an overload.



- Do not insert hands or other bodily parts in moving components. Stop the machine and secure with a master switch (lock).

Procedure during a device malfunction

1. Press red push button "Feed OFF"
2. Press red push button "Milling spindle OFF"
3. Switch the master switch to OFF
4. Wait for approximately 30 seconds
5. Resume the normal operating mode (see Chapter 6.2)

Note

A serious fault is present if the device malfunction could not be rectified after applying this procedure. In this instance, the machine must be switched fully off and the master switch must be secured with a padlock.

Please contact the N.KO to rectify the fault.

6.5 Servicing

The UZ20 must be cleaned weekly or more frequently as required.



- The machine must be switched off and secured prior to servicing work (→ power off throughout the system)
- Cleaning personnel may **not** open the switch cabinet.
- Cleaning personnel are to orient themselves upon the instructions in the Operating Manual

Procedure during cleaning

a) Before cleaning:

1. Switch off UZ20 in accordance with instructions (see Chapter 6.1, Switching the machine off)
2. Secure the master switch with a padlock

b) Cleaning

1. Clean turnings out of the castor table and milling spindle zone. The table must be leant forwards to do this (see Chapter 6.6, Changing reversing plates)
2. Clean the feed wheel
3. Empty the turnings drawer

c) After cleaning

1. Insert the turnings drawer
2. Swivel the table back into its working position (see Chapter 6.6, Changing reversing plates)

6.6 Maintenance



- The machine must be switched off and secured prior to maintenance work (→ power off throughout the system).



- The person who carries out maintenance is responsible for maintenance of the UZ20.
- If unclarities arise during maintenance then the person who is carrying out maintenance must immediately contact the N.KO .The manufacturer / supplier is not liable for any consequential damage that occurs when the N.KO contact point was not contacted.
- Procedure for switching on and off in accordance with the Operating Manual and instructions for maintenance work must be complied with for all work that relates to machine operation, production or adjustment and safety-relevant aspects of setting up as well as inspection, servicing and repair.
- Modifications to the UZ20 with regard to the supplied circuit wiring diagrams are only authorised after having obtained approval in writing from N.KO.

a) Lubrication

The feed and milling spindle variator gearboxes are lifelong lubricated.

Note

For checking: Feed lubrication is OK if oil can be seen in the viewing glass during operation.

The following three grease nipples must be greased weekly:

- Grease nipple on the left hand side of the gravitation meter (see Page 4, Item 8). The castor table is folded up for this (see Changing reversing plates in this Chapter).
- The grease nipple on the handwheel of the feed unit height adjustment (see Page 6, Item 4).
- Grease nipple on the handwheel (see Page 7, Item 3).

The grease nipples are fitted so that they can easily be seen.



Every time before opening the machine:
Switch off the UZ20 as described in
Chapter 6.1

b) Changing reversing plates

1. Press red push button "Feed OFF"
2. Press red push button "Milling spindle OFF"
3. Switch off the master switch and secure with a padlock
4. **Carefully** swivel the feed unit (1) in the direction of the arrow up to the stop. **Never** let the unit drop. Hazard of breaking.

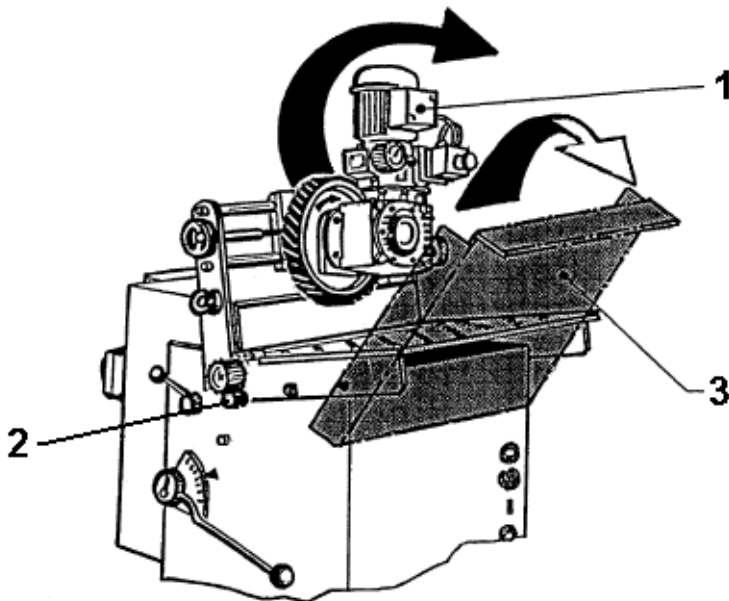

5. Use a spanner to slacken the WAF 19 nuts (2) on both sides of the machine



If you own the "Table extension" optional extra, open the table in
accordance with the instructions in Chapter 7.1, Table extension.

6. Swivel the ball castor table (3) fully in the direction of the arrow

7. Use a hexagon socket screw key to slacken all carbide reversing plates on the milling head and remove them (screws with left-hand thread)

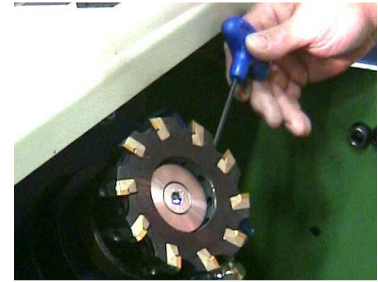

8. Thoroughly clean **all** plate seats with compressed air

9. Reinstall or replace the cleaned carbide reversing plates. Do not overtighten the plates.

10. Carefully swivel back the ball castor table (3) and tighten the nuts (2) on both sides. **Never** let the table drop.

11. **Carefully** swivel back the feed unit (1). **Never** let the unit drop. Hazard of breaking.

Note

The quality of the milled surface is dependant upon this procedure (cleanliness of the milling head and carbide reversing plates). This procedure must be repeated if results of milling are bad.

Please make contact with the N.KO contact point to obtain advice on the purchase of reversing plates.

c) Maintenance of mechanical components

- The specialist personnel who carry out the maintenance are to switch off the master switch and secure it with a padlock prior to the maintenance work
- The machine must be labelled with a warning sign at the master switch
- Only original replacement parts are to be used
- Slackened threaded joints are always to be tightened



- If it is necessary to disassemble safety devices then they must be refitted and inspected immediately after the maintenance work has been completed

d) Maintenance of electrical components



- A skilled electrician should perform maintenance of electrical components. This skilled electrician must work in accordance with the pertinent regulations.
- A visible separation point must be made between the mains power supply and UZ20 by pulling out the electrical plug whenever maintenance work is performed.
- The machine must be labelled with a warning sign at the master switch
- Original replacement parts are to be used
- The supplied circuit wiring diagrams are binding and must be complied with
- Modifications to the UZ20 with regard to the supplied circuit wiring diagrams are only authorised after having obtained approval in writing from N.KO.
- All alterations degrade the machine safety functions. Responsibility for any consequential damage that occurs to the limb and life of persons and animals as well as damage to material assets is borne solely by the specialist who undertakes this maintenance and modifications.
- Defects reported by other persons (cleaning personnel etc.) are to be rectified without delay.

7. Additional notes

7.1 Optional extras



All optional extras may only be fitted when the machine is switched off.

a) Synthetic material overlay for the guide rails

Certain materials such as stainless steel and aluminium sheets with polished surfaces have bad antifriction properties.

For this reason, N.KO supplies synthetic material plates suitable for laying on the guide rails.

These synthetic material plates are stuck onto the clean degreased guide rails with double-sided adhesive tape.

Note

Note that the chamfer depth is reduced by the amount of the thickness of the synthetic material plates when synthetic material plates are used. This means that the chamfer depth must be set deeper by this thickness.

Remove lateral burrs from the workpiece face sides beforehand, otherwise they will damage the synthetic material overlays.

b) Circular milling device 15-60

A circular milling device can also be fitted to the UZ20. It allows edges to be machined on the face sides of round materials (pipes, round rods, etc.) with diameters 15 – 60 mm.

Assembly:

1. **Carefully** swivel the feed unit in the direction of the arrow up to the stop (1). **Never** let the unit drop. Hazard of breaking.
2. Place the circular milling device (2) on the lower guide rail as shown in the sketch
3. Fasten the device to the side panel with two hexagonal socket screws (3)

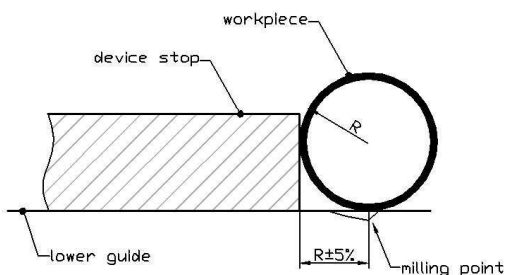
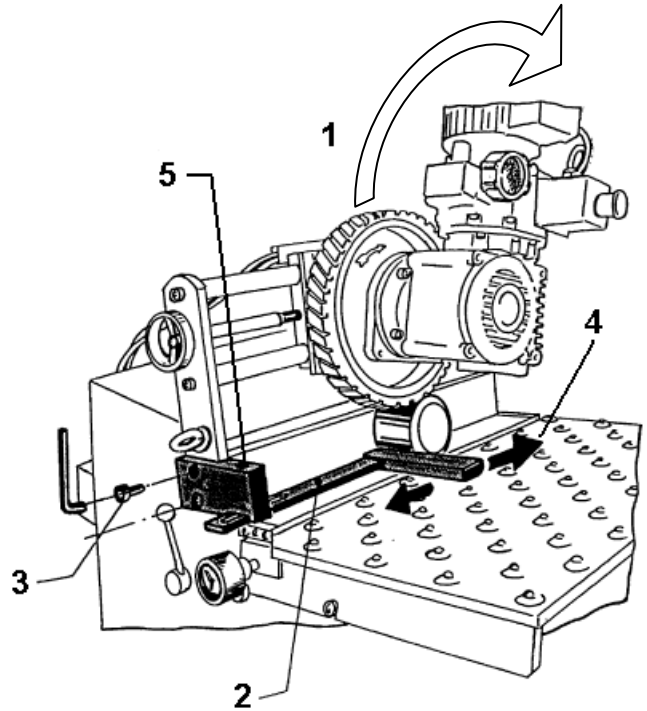

4. Push the device stop to the side (4) so that the distance from the stop to the milling point is equal to the workpiece radius ($\pm 5\%$)



5. Fix the device stop in place with a screw (5)



6. Carefully swivel back the feed unit and set up the machine in accordance with Chapter 6.2.

For machining, switch on the UZ20 in accordance with Chapter 6.1, move the round material up to the stop as shown in the picture and run it for a few rotations.

c) Circular milling device 60-160

In addition to *circular milling device 15-60*, a device can be fitted that allows the face side of edges to be machined with diameters of 60 – 160 mm. Both devices are delivered together.

Assembly:

1. **Carefully** swivel the feed unit as described in Sect.1 on the previous page.

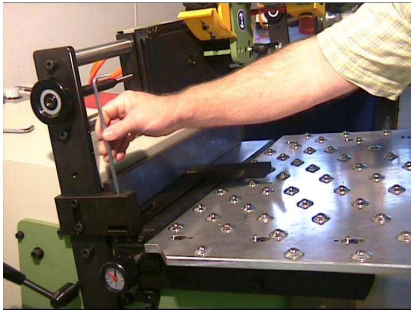

2. Slacken *device stop 15-60* with screw

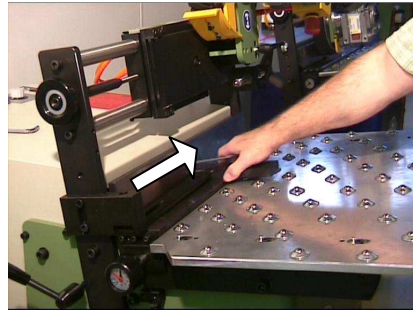

3. Remove *device stop 15-60*

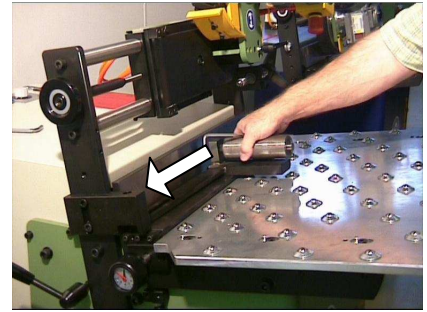

4. Insert *device stop 60-160*



5. Set up the *device stop* as described in Sect. 4 on the previous page



6. Fix the *device stop* in place with a screw

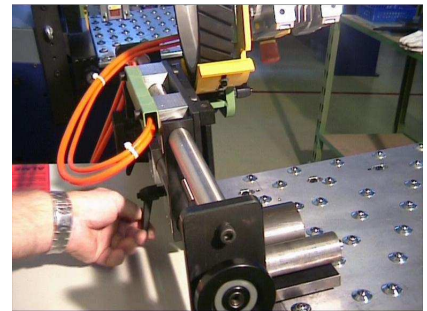

7. Push the feed wheel (in accordance with Chapter 6.2, b) so that the wheel rests well

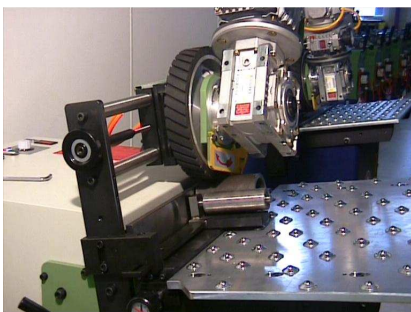

8. Continue as described in Sect. 6 on the previous page



d) Table extension

Plate chamfer machines UZ20 can also be delivered with a table extension. This requires that the basic machine is anchored (hole distances in accordance with the sketch).

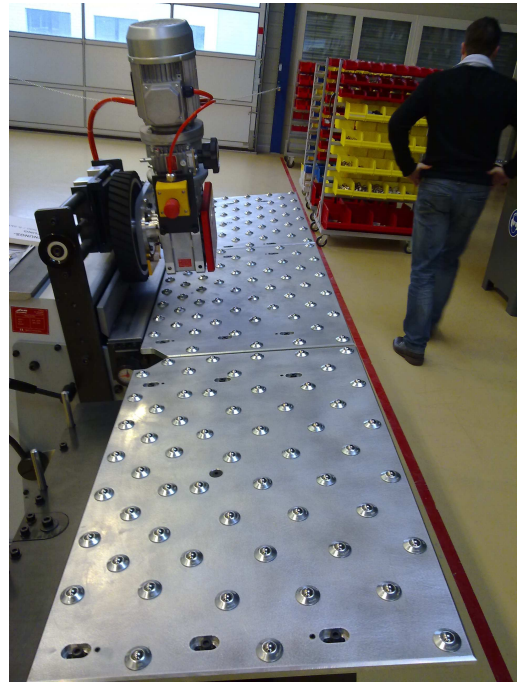
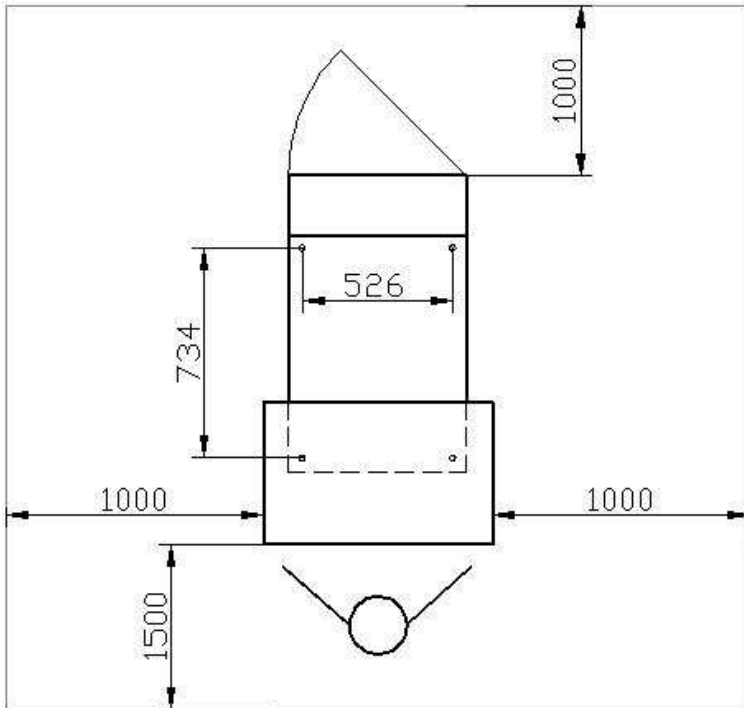

Exercise care when opening the machine with table extension.
Proceed in accordance with the following instruction when the machine is opened.



a) Slacken the double nuts (1.) and counterhold the table at the upper guide rail (2.)



b) Slowly release the counterpressure

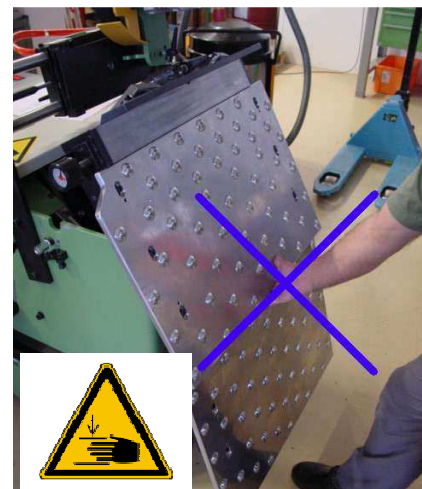

c) Never open the machine by inserting hands between the folding and main tables Hazard of crushing.



7.2 Service

Please contact NKO for service or maintenance work on the plate chamfer machine.

7.3 Disposal

This machine must be disposed of in accordance with local applicable legal requirements at the end of its working life.

It is recommended that contact be made with a specialist disposal company.

The UZ20 can be fully separated into single parts and does not contain any materials that have to be disposed of as hazardous waste.

8. Replacement parts

The following components are wearing parts and can (as can all other single parts) be ordered as required.

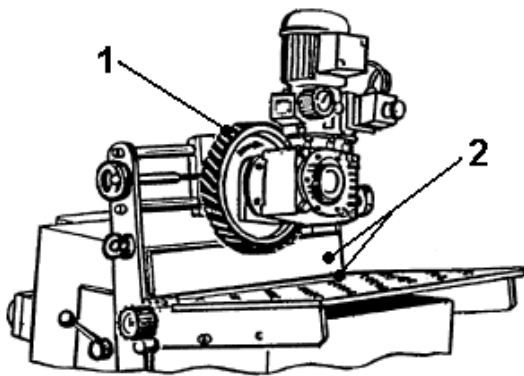

- 1) Feed wheel
- 2) Upper and lower guide rails

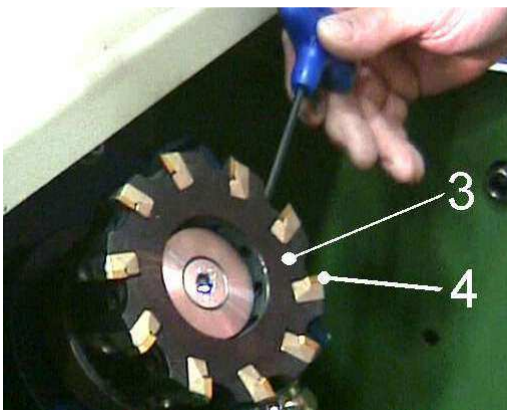

- 3) Knife head (milling head)
- 4) Reversing plate and support plates
(Can be ordered directly from reversing plate suppliers)